

Schlüter®-SCHIENE

Finishing profiles for floor and wall coverings
for reliable edge protection

1.1

Product data sheet

Application and function

Schlüter-SCHIENE is an extruded profile that finishes and protects the edges of tiled coverings in addition to other suitable surface materials.

Applications include: transitions between different surface coverings (e.g. tile to carpet); dado coverings; edge protection at expansion joints; decorative edging for external wall corners and stairs; as well as a finish edging for all types of surfaces, such as carpet, parquet, laminates, natural stone coverings, or cold cured resin coverings.

The profile's unique design combines specific angle positions and material wall thicknesses to transmit point loads into the substrate and surface covering, thus protecting the covering's edges against damage.

The joint spacer, which is integrated from a profile height of 6 mm (8 mm for SCHIENE-ES), defines a joint chamber with the tile. The anchoring leg of SCHIENE, in all material types, can be punched with a special radius perforation "R" so that the profile can be used to form curves.

Material

The profile is available in the following finishes:

- E = stainless steel
V2A, material no. 1.4301 = AISI 304
V4A, material no. 1.4404 = AISI 316L
- EB = brushed stainless steel
- A = aluminium
- M = brass
- AE = anodised aluminium
- AC = colour coated aluminium
- TS = textured finished aluminium
- MC = chrome-plated brass



Material properties and areas of application:

In special cases, the suitability of materials must be verified based on the anticipated chemical, mechanical, and/or other stresses.

Schlüter-SCHIENE in versions -E (stainless steel), -EB (brushed stainless steel), -A (aluminium), -AE (anodised aluminium) and -M (brass) are suitable for installation in wall and floor areas, while the profile versions -AC (colour coated aluminium), -TS (textured finished aluminium) and -MC (chrome-plated brass) are only suitable for installation in wall coverings, where they provide durable and visually appealing edge protection.

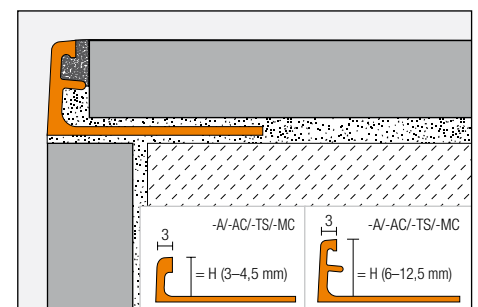
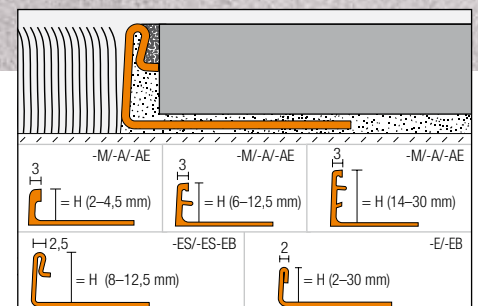



Profiles for use in walls and floors

Schlüter-SCHIENE-M are profiles made of brass. Minor manufacturing flaws are unavoidable on their untreated surfaces. They are suitable for absorbing high mechanical stresses, e.g. as an edge protection for movement joints in industrial floor coverings with conveyor traffic. Brass is resistant to virtually all chemicals used in conjunction with tile coverings.

Brass that is exposed to air will oxidise, resulting in a natural patina. Exposure to moisture or aggressive substances may result in heavy oxidation and staining at the surface.

Schlüter-SCHIENE-A are profiles made of aluminium. Technically, these are so-called semi-finished products, in which minor manufacturing traces also cannot be avoided. The suitability of the profiles should be reviewed based on the anticipated chemical stresses. Aluminium is sensitive to alkaline media. Cementitious materials, in conjunction with moisture, become alkaline. Since aluminium is sensitive to alkaline substances, exposure to the alkali (depending on the concentration and time of exposure) may result in corrosion (aluminium hydroxide formation). For this reason, remove mortar or grouting material immediately from all visible areas and do not cover freshly installed coverings until the adhesive and grout have dried. Solidly embed the profile in the setting material to prevent alkaline water from accumulating in small cavities.

In case of more demanding visual requirements, SCHIENE-AE or -EB with post-treated, high-quality finishes are available.

Schlüter-SCHIENE-AE, made of anodised aluminium, has an anodised surface finish that will not change under normal circumstances. The finish may be damaged by aggressive substances or abrasive stresses. The surface, however, is susceptible to scratching and wear and may be damaged by tile adhesive, mortar, or grouting material. Therefore, setting materials must be removed immediately. Otherwise, the description regarding aluminium applies.

Schlüter-SCHIENE-E is made of roll formed V2A (material no. 1.4301) or V4A (material no. 1.4404) stainless steel. The profile structure therefore varies slightly from the extruded brass and aluminium versions. SCHIENE-E is highly durable and especially suited for application areas that must be

resistant to chemicals and acids, such as the food industry, breweries, dairies, industrial kitchens, and hospitals.

Depending on the anticipated chemical stresses, customers can choose between the alloy materials 1.4301 (V2A) or 1.4404 (V4A). The use of V4A is recommended if consistent exposure is expected, for example in the case of swimming pools (fresh water). Even stainless steel of quality 1.4404 is not resistant to all chemical stresses. Substances such as hydrochloric or hydrofluoric acid or certain chloride and brine concentrations may cause damage. In certain cases, that also applies to seawater pools. Special anticipated stresses should therefore always be verified in advance.

Profiles for use in walls

Schlüter-SCHIENE-MC (chrome plated solid brass) is especially well suited for wall corners and transitions. It is ideal for matching chrome fixtures. Surface areas must be protected against abrasion or scratching. Remove all adhesive and grouting material immediately.

Schlüter-SCHIENE-AC (colour coated aluminium): The aluminium is pre-treated (chrome-plated) and powder-coated with a polyurethane covering. The coating is colour-stable, as well as UV- and weather-resistant. Visible edges should be protected against abrasion.

The surfaces of Schlüter-SCHIENE-TS profiles (textured finished aluminium) have a natural appearance (see Schlüter-SCHIENE-AC for further properties).

Schlüter-SCHIENE-ACG / -ACGB / -AT / -ATG / -ATGB / -AK / -AKG / -AKGB / -AM / -AMG / -AMGB / -ABGB / -AGSG / -AGRB (anodised aluminium): The aluminium features an anodised finish that retains a uniform appearance during normal use. Surface areas must be protected against abrasion or scratching. Aluminium is sensitive to alkaline media. Cementitious materials, in conjunction with moisture, become alkaline, which may result in corrosion depending on the concentration and length of exposure (aluminium hydroxide formation). For this reason, remove mortar or grouting material immediately from all visible areas and do not cover freshly installed coverings with foil. Solidly embed the profile in the setting material to prevent alkaline water from accumulating in small cavities.

Installation

1. Select the profile height according to the tile thickness and the installation method.
2. Apply tile adhesive to the area where the tile covering will end, using a notched trowel.
3. Press the trapezoid-perforated anchoring leg of the profile firmly into the adhesive and align it.
4. Trowel additional tile adhesive over the trapezoid perforated anchoring leg to ensure full coverage.
5. Fully embed the adjoining tiles and adjust them in such a way that the upper lip of the profile is flush with the tile.
Note: The profile may slightly protrude or be recessed in the wall area to offset dimensional variations in the covering material. In floor areas, the profile should not be higher than the tiled surface, but rather up to approx. 1 mm lower.
6. The tile is set to the lateral joint spacer, which creates an evenly spaced joint of 1.5 mm. In the case of profiles without joint spacer, a joint of approx. 1.5 mm is recommended.
7. Completely fill the space between the tile and the profile with grout.



Product overview - Profiles for use in walls

Colours:

- W = white
- BW = brilliant white
- HB = light beige
- BH = bahama
- SP = soft peach
- G = grey
- HG = light grey
- PG = pastel grey
- RB = red brown
- SB = black brown
- GM = grey metallic
- GS = graphite black
- MBW = matte brilliant white
- MGS = matte graphite black
- ACG = polished chrome anodised aluminium
- ACGB = brushed chrome anodised aluminium
- AT = matte titanium anodised aluminium
- ATG = polished titanium anodised aluminium
- ATGB = brushed titanium anodised aluminium
- (Colour may differ from other Schlüter profiles in ATGB finish)
- AK = matte copper/bronze anodised aluminium
- AKG = polished copper/bronze anodised aluminium
- AKGB = brushed copper/bronze anodised aluminium
- AM = matte brass anodised aluminium
- AMG = polished brass anodised aluminium
- AMGB = brushed brass anodised aluminium
- ABGB = brushed antique bronze anodised aluminium
- AGSG = polished chrome black anodised aluminium
- AGRB = brushed chrome graphite anodised aluminium
- TSI = aluminium, textured natural ivory
- TSC = aluminium, textured natural cream
- TSBG = aluminium, textured natural beige grey
- TSB = aluminium, textured natural beige
- TSSG = aluminium, textured natural stone grey
- TSG = aluminium, textured natural grey
- TSOB = aluminium, textured natural bronze
- TSLA = aluminium, textured natural light anthracite
- TSDA = aluminium, textured natural dark anthracite
- TSR = aluminium, textured natural rustic brown

Schlüter®-SCHIENE-A

AE = anodised aluminium Length supplied: 2.5 m

H = mm	6	8	10	11	12.5
ACG	•	•	•	•	•
ACGB	•	•	•	•	•
AT	•	•	•	•	•
ATG	•	•	•	•	•
ATGB	•	•	•	•	•
AK	•	•	•	•	•
AKG	•	•	•	•	•
AKGB	•	•	•	•	•
AM	•	•	•	•	•
AMG	•	•	•	•	•
AMGB	•	•	•	•	•
ABGB	•	•	•	•	•
AGSG	•	•	•	•	•
AGRB	•	•	•	•	•

Schlüter®-SCHIENE-A

AE = anodised aluminium Length supplied: 3 m

H = mm	6	8	10	11	12.5
ACG	•	•	•	•	•

Schlüter®-SCHIENE-MC

MC = chrome plated brass Length supplied: 2.5 m

H = mm	6	8	10	11	12.5
MC	•	•	•	•	•

Schlüter®-SCHIENE-AC

AC = colour coated aluminium Length supplied: 2.5 m

H = mm	3	4.5	6	8	10	11	12.5
W	•	•	•	•	•	•	•
BW	•	•	•	•	•	•	•
HB	•	•	•	•	•	•	•
BH	•	•	•	•	•	•	•
G	•	•	•	•	•	•	•
HG	•	•	•	•	•	•	•
PG	•	•	•	•	•	•	•
RB	•	•	•	•	•	•	•
SB	•	•	•	•	•	•	•
GM	•	•	•	•	•	•	•
GS	•	•	•	•	•	•	•
MBW	•	•	•	•	•	•	•
MGS	•	•	•	•	•	•	•

Schlüter®-SCHIENE-AC

AC = colour coated aluminium Length supplied: 3 m

H = mm	6	8	10	11	12.5
W	•	•	•	•	•
BW	•	•	•	•	•
PG	•	•	•	•	•
GS	•	•	•	•	•
MBW	•	•	•	•	•

Schlüter®-SCHIENE-TS

TS = aluminium, textured finished

Length supplied: 2.5 m

H = mm	6	8	10	11	12.5
TSI	•	•	•	•	•
TSC	•	•	•	•	•
TSBG	•	•	•	•	•
TSB	•	•	•	•	•
TSSG	•	•	•	•	•
TSG	•	•	•	•	•
TSOB	•	•	•	•	•
TSLA	•	•	•	•	•
TSDA	•	•	•	•	•
TSR	•	•	•	•	•



Schlüter®-SCHIENE-TS (TSC)

 Profiles with radius perforation; see current Illustrated Price List for details.



Product overview - Profiles for use in walls and floors

Schlüter®-SCHIENE -M/ -A / -AE

M = brass / A = aluminium / AE = anodised aluminium
Length supplied: 2.5 m

Material	M	A	AE
H = 2 mm		•	•
H = 3 mm	•	•	•
H = 4.5 mm	•	•	•
H = 6 mm	•	•	•
H = 7 mm		•	•
H = 8 mm	•	•	•
H = 9 mm	•	•	•
H = 10 mm	•	•	•
H = 11 mm	•	•	•
H = 12.5 mm	•	•	•
H = 14 mm		•	•
H = 15.5 mm	•	•	•
H = 16.5 mm	•	•	•
H = 17.5 mm	•	•	•
H = 20.5 mm	•	•	•
H = 21 mm		•	•
H = 22.5 mm	•	•	•
H = 25 mm	•	•	•
H = 27.5 mm		•	•
H = 30 mm	•	•	•

Length supplied: 1 m

Material	M	A	AE
H = 4.5 mm	•	•	•
H = 6 mm	•	•	•
H = 8.5 mm	•	•	•
H = 10 mm	•	•	•
H = 12.5 mm	•	•	•
H = 15 mm	•	•	•

Length supplied: 3 m

Material	M	A	AE
H = 6 mm	•	•	•
H = 8 mm	•	•	•
H = 10 mm	•	•	•
H = 11 mm		•	•
H = 12.5 mm	•	•	•

Schlüter®-SCHIENE-E

E = stainless steel / E V4A = stainless steel 1.4404 (V4A) / EB = brushed stainless steel

Length supplied: 2.5 m

Material	E	E V4A	EB
H = 2 mm	•		
H = 3 mm	•		
H = 4.5 mm	•	•	
H = 6 mm	•	•	•
H = 7 mm	•		
H = 8 mm	•	•	•
H = 9 mm	•		
H = 10 mm	•	•	•
H = 11 mm	•	•	•
H = 12.5 mm	•	•	•
H = 14 mm	•	•	
H = 15.5 mm	•	•	
H = 16 mm	•	•	
H = 17.5 mm	•	•	
H = 20 mm	•	•	
H = 22.5 mm	•	•	
H = 25 mm	•	•	
H = 30 mm	•	•	

Length supplied: 1 m

Material	E
H = 6 mm	•
H = 8 mm	•
H = 10 mm	•
H = 11.5 mm	•
H = 12.5 mm	•

Length supplied: 3 m

Material	E	EB
H = 6 mm	•	•
H = 8 mm	•	•
H = 10.5 mm	•	•
H = 11 mm	•	•
H = 12.5 mm	•	•

Schlüter®-SCHIENE-ES

Stainless steel profile with joint spacer

E = stainless steel / EB = brushed stainless steel

Length supplied: 2.5 m, 3 m

Material	E	EB
H = 8 mm	•	•
H = 10.5 mm	•	•
H = 11.5 mm	•	•
H = 12.5 mm	•	•

Length supplied: 1 m

Material	E
H = 8.5 mm	•
H = 10.5 mm	•
H = 11.5 mm	•
H = 12.5 mm	•





Maintenance

The profile requires no special maintenance or care. Do not use abrasive cleaning agents on the sensitive surfaces. Oxidation films on brass or aluminium may be removed with a common polishing agent; however, they do reoccur. Damaged anodised finishes may only be repaired by recoating. Stainless steel surfaces develop a sheen when treated with a chrome polishing agent etc.

Stainless steel surfaces exposed to the environment or aggressive substances should be cleaned periodically using a mild household cleaner. Regular cleaning maintains the neat appearance of stainless steel and reduces the risk of corrosion. All cleaning agents must be free of hydrochloric and hydrofluoric acid. Avoid the contact with other metals, such as regular steel, to prevent corrosion. This also includes installation tools such as trowels or steel wool, e.g. for the removal of mortar residue.

We recommend the use of the stainless steel cleaning polish Schlüter-CLEAN-CP.





Text template for tenders:

_____linear metres of Schlüter-SCHIENE as a finishing and edge protection profile made of

- -M = brass
- -A = aluminium
- -AE = anodised aluminium

with a trapezoid perforated anchoring leg connected to an 87° angled finishing section, which widens to a sloped top flange and features an integrated joint spacer to create the joint cavity.

_____linear metres of Schlüter-SCHIENE-E as a finishing and edge protection profile made of

- -E = stainless steel 1.4301 (V2A)
- -E V4A = stainless steel 1.4404 (V4A)
- -EB = brushed stainless steel 1.4301 (V2A)

with trapezoid perforated anchoring leg, angled (87°) wall section, and sloped top flange, made of roll formed stainless steel.

Profile height: _____mm
 Art.-No.: _____

- in individual lengths of _____m
- in various lengths, as required
- to protect the edges of coverings at adjoining expansion joints
- as covering surround
- to position
- according to detail drawing

...to be supplied and professionally installed while observing the manufacturer's operating and installation instructions.

Material: _____/m
 Labour: _____/m
 Total: _____/m

Text template for tenders:

_____linear metres of Schlüter-SCHIENE-ES as a finishing and edge protection profile made of

- -E = stainless steel 1.4301 (V2A)
- -EB = brushed stainless steel 1.4301 (V2A)

with a trapezoid perforated anchoring leg and an adjoining finishing leg at an 87° angle with a double-seamed head of stainless steel strip material and a joint spacer to form a joint chamber...

Profile height: _____mm
 Art.-No.: _____

- in individual lengths of _____m
- in various lengths, as required
- to protect the edges of coverings at adjoining expansion joints
- as covering surround
- for position
- according to detail drawing

...to be supplied and professionally installed while observing the manufacturer's operating and installation instructions.

Material: _____/m
 Labour: _____/m
 Total: _____/m

Text template for tenders:

_____linear metres of Schlüter-SCHIENE as a finishing and corner profile for wall coverings made of

Material:

- MC = chrome plated solid brass
- TS = textured coated aluminium
- AC = colour coated aluminium
- ACG = polished chrome anodised aluminium
- ACGB = brushed chrome anodised aluminium
- AT = matte titanium anodised aluminium
- ATG = polished titanium anodised aluminium
- ATGB = brushed titanium anodised aluminium

(Colour may differ from other Schlüter profiles in ATGB finish)

- AK = matte copper/bronze anodised aluminium
- AKG = polished copper/bronze anodised aluminium
- AKGB = brushed copper/bronze anodised aluminium
- AM = matte brass anodised aluminium
- AMG = polished brass anodised aluminium
- AMGB = brushed brass anodised aluminium
- ABGB = brushed antique bronze anodised aluminium
- AGSG = polished chrome black anodised aluminium
- AGRB = brushed chrome graphite anodised aluminium

with a trapezoid perforated anchoring leg connected to an 87° angled finishing section, which widens to a sloped top profile flange and features an integrated joint spacer to create a joint cavity.

Profile height: _____mm
 Art.-No.: _____

- in various lengths, as required
- as covering surround for external wall corners
- for position
- according to detail drawing

...to be supplied and professionally installed while observing the manufacturer's operating and installation instructions.

Material: _____/m
 Labour: _____/m
 Total: _____/m