

# Concrete Grinder 1900W

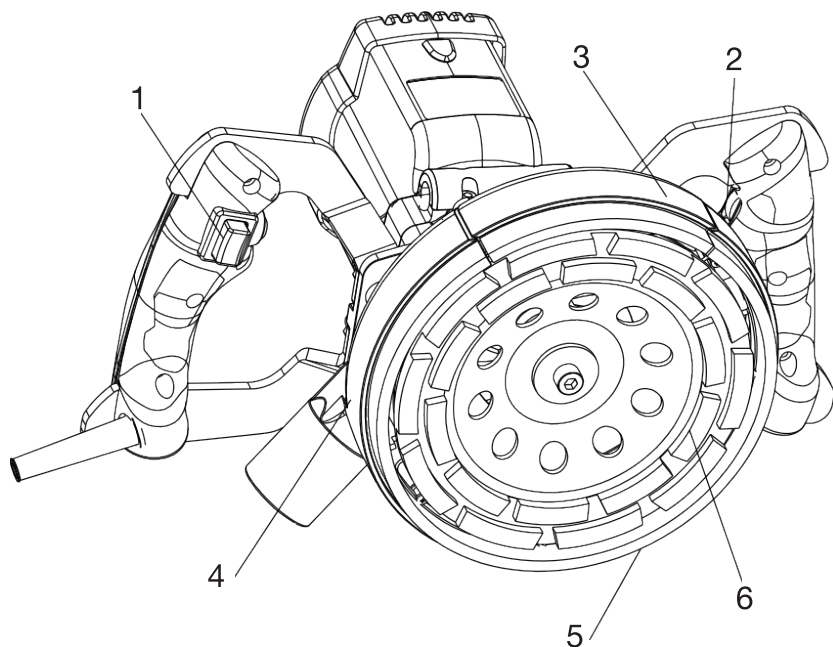

 Read before use





### Spare Part List

1	Motor power button
2	Speed control knob
3	Front anti-dust cover board
4	Anti-dust cover
5	Anti-dust brush
6	Diamond cup wheel

## INDEX

- ① Safety Warnings
- ② Specification
- ③ Using Instructions
- ④ Cleaning and Maintenance
- ⑤ Environmental Protection
- ⑥ Warranty

### 1. Safety Warnings

Please keep the workplace clean and bright;

Please keep the grinder away from the high temperature source, and flammable, explosive, corrosive liquids and gases;

Please protect the grinder from damage by external force or sharp objects, and pay attention to prevent falling damage;

Please don't touch the cup wheel by hand during working, and prevent the wire from getting into the cup wheel ;

Please don't keep the grinder exposed to rain and humidity for a long time;

When using the grinder, please wear dust masks and goggles;

This grinder is only used for concrete floor surface. Please don't apply to using on other materials

Please keep the cup wheel sharp and clean and replace them in time;

Please keep the cup wheel clean and working freely, and keep the track clean and sliding freely.

Please put idle grinder outside the reach of children, and don't let someone unfamiliar with the grinder or who doesn't know the instructions operate the grinder.

Please send your grinder to professional maintenance personnel, and must use the same spare parts for replacement;

Please keep the handles clean, dry and oil-free.







### 2. Specification

Model	CG1900
Measurement	384mm×227mm×307mm
Net Weight	6.6Kg
Power	1900W
Voltage/Frequency	230V/50-60HZ
Speed	0-3000r/min

Manufacturer reserves the right to change specifications without notice.  
Specifications may differ from country to country

### Symbols

The following are the icons that are used for the tool. Make sure you fully understand them before using them.

	Read before use		Wear safety gloves
	CE mark		Wear hearing protectors
	Caution		Wear safety glasses
	Conforms to WEEE		

### 3. Using Instructions

3.1 Connect an external suction pipe to the internal dust outlet, secure they are completely connected.

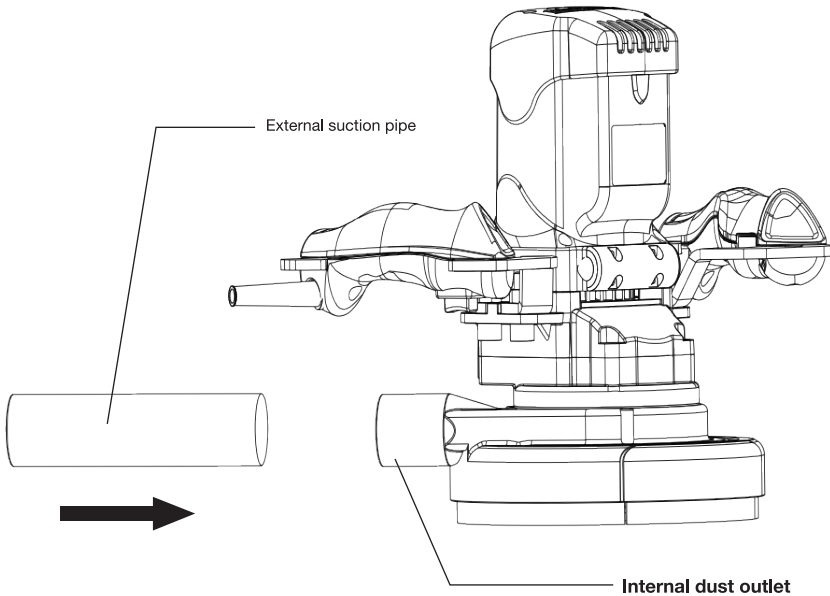

3.2 Hold the handles by both hands and put your concrete grinder on working face with a slight downward pressure through handles. Then press the motor power button and self-locking button to start the machine (do not loose your hands). The machine gets ready for polishing work as soon as it becomes stable. For different work demands, adjust the rotate speed by twirling the speed control knob using the left hand finger. The machine must be horizontal in working process.

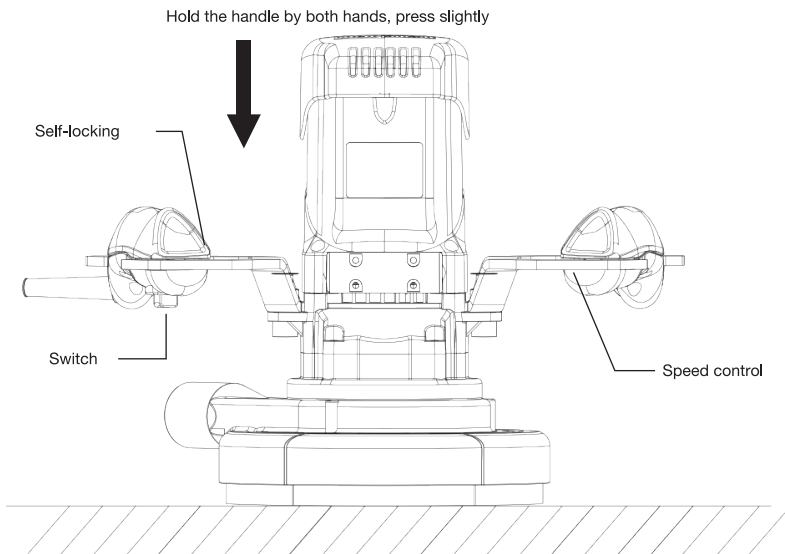

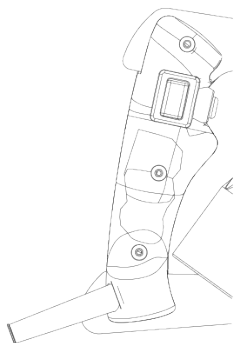

Press motor power button

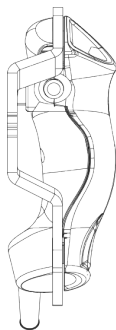

Press self-locking button

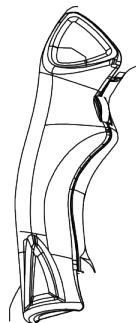

Adjust speed control knob

**3.3** Take the front anti-dust cover board apart from the anti-dust cover towards the direction showing by an arrow, in order to expose the diamond cup wheel for corner grinding demand. And then repeat Step 2, it gets ready to work as soon as it becomes stable

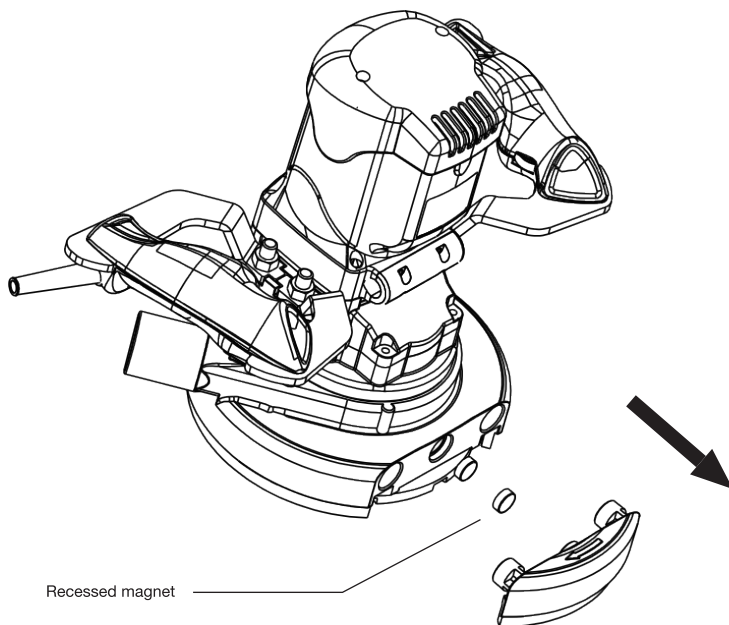

Recessed magnet

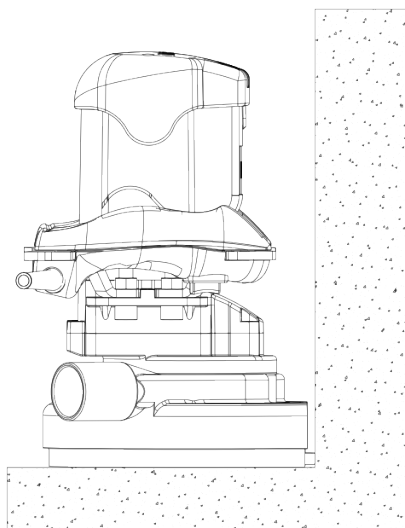

Edge & Corner operating sketch

**3.4** Once you need stop working, please loose your hands and let the machine stay where it is for 30 seconds. Then Press the motor power button after the dust inside of the anti-dust cover has been well collected and cleaned.

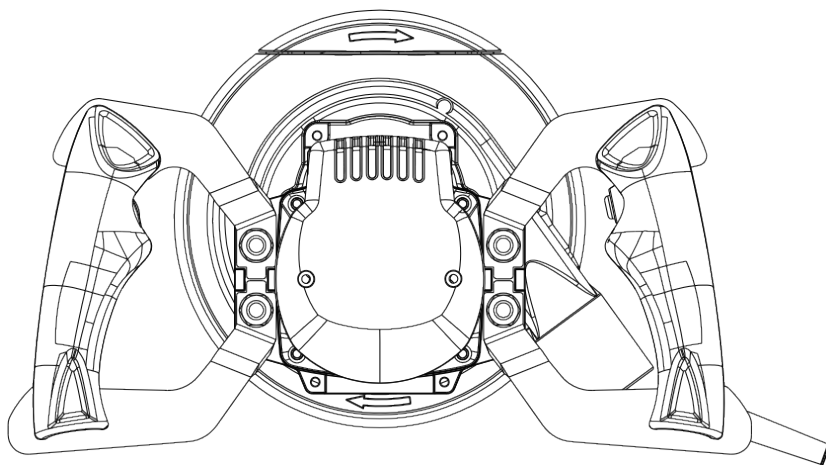

Let the machine stay where it is for 30 seconds, and then press motor power button

**3.5** For replacing the cup wheel, you should first take the old cup wheel down by following steps, **(3.5.1)** Put both ends of the Y type wrench into holes around the edge of the diamond pad. **(3.5.2)** Fasten the Hexagonal wrench to the lock screw. **(3.5.3)** Rotate these both wrenches toward opposite directions. **(3.5.4)** Take the lock screw off. And then installing a new cup wheel by repeating above steps, you will achieve it easily.

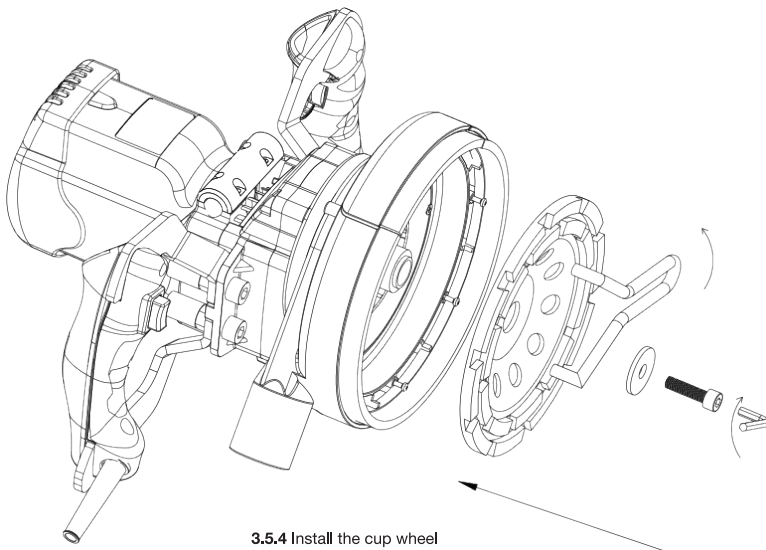
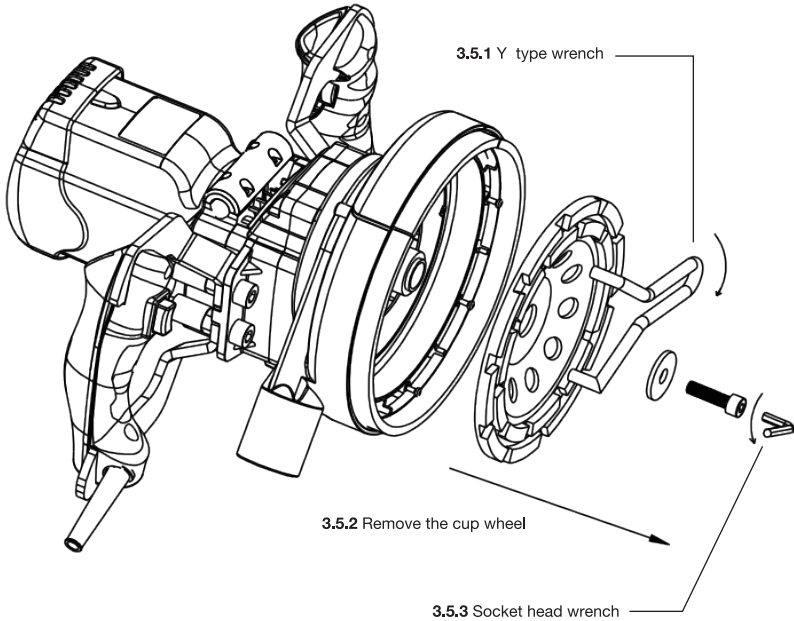

#### 4. Cleaning and Maintenance

- **Maintain your grinder with care.** Clean the grinder immediately after use. Keep the grinder clean for best and safest performance. When maintaining this grinder, only the manufacturer's original replacement parts may be used.
- **Store idle equipment.** When not in use, the grinder should be stored in a dry location to prohibit rust.

#### 5. Environmental Protection

- Do not dispose of electrical appliances in the household waste.
- Follow the local provisions for the disposal of electrical or battery products.
- Valuable materials can be recovered by recycling.
- The electrical or battery components used for construction are in accordance with the regulation European Directive 2012/19 / EU on waste electrical and electronic equipment and transposition into national law., used electrical appliances must be collected separately and recycled in an environmentally sound manner.
- Contact us for further information.



#### 6. Warranty

- The guarantee covers all manufacturing or assembly defects in accordance with the legislation in force. The guarantee does not cover malfunctions caused by improper use, overloads, failure to follow the operating instructions and normal wear and tear.
- For more details and information, consult the general guarantee conditions at [www.bihuitools.com](http://www.bihuitools.com)